

RoHS Compliant

REV.	ECN NO.	DESCRIPTION	REVISER	DATE
A0		新版本	H.H.F	15-07-06

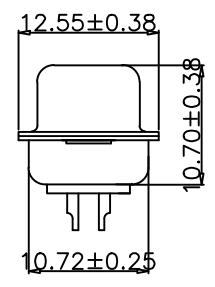
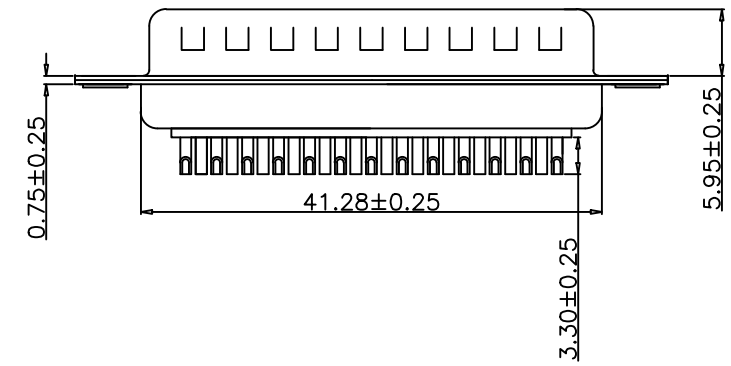
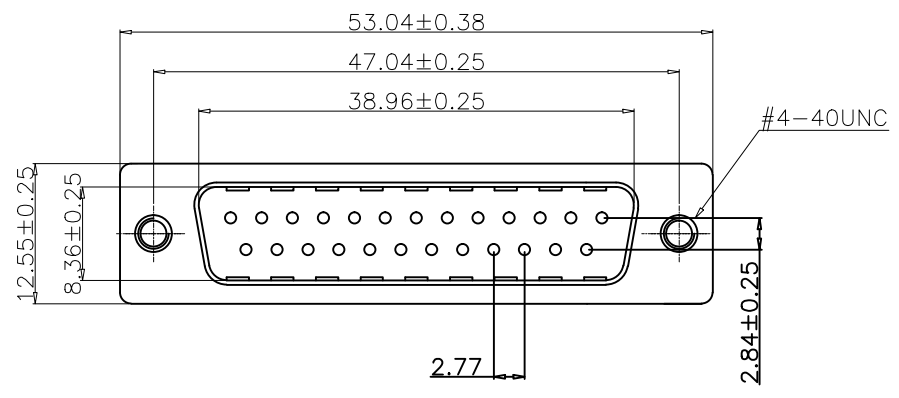

NOTE:

- MATERIALS AND FINISHED  
 INSULATOR : PBT+30% GF UL 94V-0,  
 SHELL : STEEL, NI OR SN FINISHED  
 CONTACT MATERIAL : BRASS, SELEVITE GOLD FINISHED  
 RIVETED INSERT: BRASS MATERIAL ,TIN FINISHED  
 WITH #4-40 THREADED ASSEMBLED
- ELECTRICAL CHARACTERISTICS  
 CURRENT RATING : 1.0 AMP DC  
 VOLTAGE RATING: 300 V DC  
 CONTACT RESISTANCE :20 MILLIOHMS MAX.  
 DIELECTRIC WITHSTANDING VOLTAGE : 500 V AC MIN.  
 INSULATION RESISTANCE : 1000 MEGAOHMS MIN.
- ENVIRONMENTAL  
 OPERATING TEMPERATURE: -55°C ~ +85°C  
 STORAGE TEMPERATURE:-55°C ~ +105°C
- HOW TO ORDER:

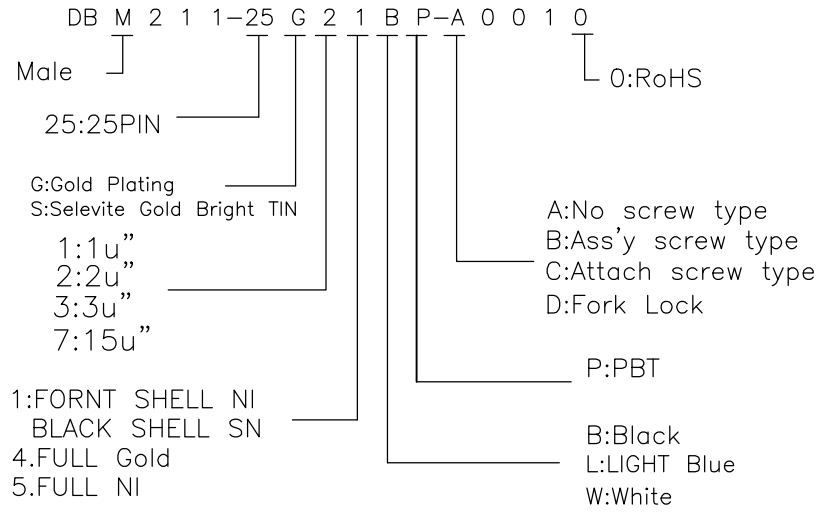

比例(Scale):1:1	图号(DWG NO.)	CELION SAS		
单位(Unit):mm	设计(Design)			H.H.F
未注公差 Tolerance Unspecified X. ±0.38 X.X ±0.35 X.XX ±0.25 X.XXX ±0.15 X.' ±2' X.XX' ±0.5' X.X' ±1'	审核(Checked)	品名(Title): DB 25公头车针焊线, 端子全金2u黑胶, 铆合光孔		
	核准(Approved)			
	页次(Sheet)	1 OF 1	料号P/N):	DBM211-25G21BP-A0010
	版次(Rev.):A0			