

TAPE REEL成品擺放方向

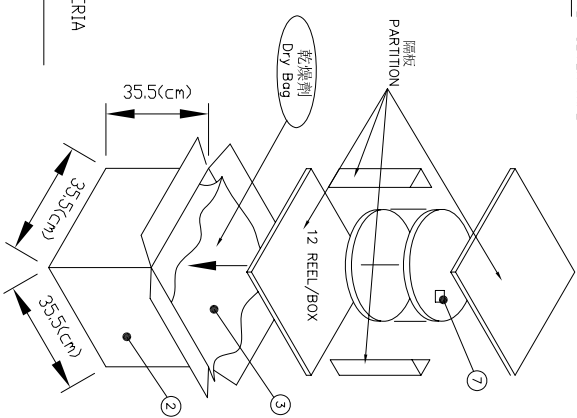

NOTES  
 1.MATERIAL: PS (Color: 透明)  
 2.DEFORMATION(變形)&DAMAGE(損壞): NA(不)  
 3.All dimensions meet EIA-481-C requirements.

ITEM 項目	PARTS NAME 零件名稱	FINISH/REMARK 處理/備註
1	CONNECTOR	12000 PCS/BOX
2	BOX	12 REEL/BOX
3	WATERPROOF BAG	1 PCS
4	REEL	1000 PCS/REEL
5	COVER TAPE	Wide=24mm
6	CARRIER TAPE	--
7	LABEL	批號標籤

# CELLION SAS

DESCRIPTION: USB 31 C TYPE FEMALE 短基板 upper SMT/DIP 包装规范

DRAWING NO: B1151020-005 PART NO.: BU5T24B3M1130

THIRD ANGLE PROJECTION	REVISION	ANGLE	UNIT	MM	DRAWN	DAVIDWU
	X	+0.50	X	±5°	N/A	CHECKED
	XX	+0.38	XX	±2°		
	XXX	+0.25	XXX	±1°		
			SHEET	3/3	APPROVED	