

REV.	LOCAS.	DESCRIPTION	DATE	DRAWN
01		INITIAL RELEASE.	2020.07.06	

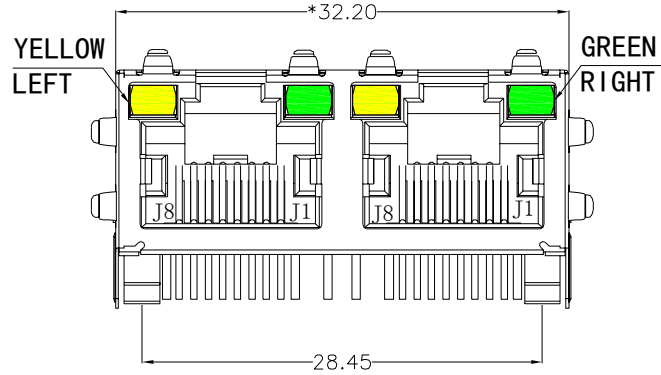

FRONT VIEW

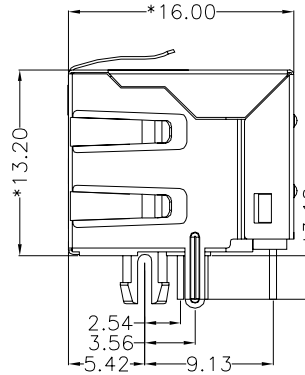

RIGHT SIDE VIEW

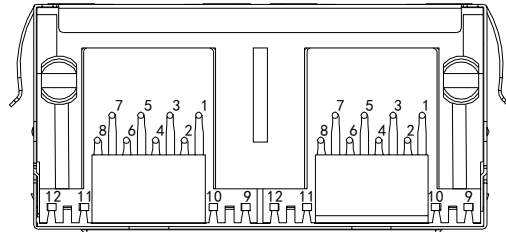

BOTTOM VIEW

**MATERIAL:**

HOUSING: PA46,UL94V-0,BLACK.  
 TERMINAL: PHOSPHOR BRONZE Ø=0.46MM, G/FU" GOLD PLATING.  
 SHIELD: C2680,T=0.20MM,20 MIN NICKEL PLATING  
 ON ALL AREA.

**MACHANICAL:**

DURABILITY: 750 CYCLES MIN,12.5MM/MINUTE.  
 INSERTION FORCE: 2.2KG.F MAX.  
 RETENTION STRENGTH : 7.7KG.F BETWEEN JACK AND PLUG.  
 OPERATING TEMPERATURE: -40°C~+85°C.  
 STORAGE TEMPERATURE: -40°C~+85°C.  
 ALL CRITICAL DIMENSIONS WITH ""

**ELECTRICAL:**

VOLTAGE: 125 VOLTS AC.  
 CURRENT RATING : 1.5AMP.  
 DIELECTRIC STRENGTH: 1000 VAC RMS 50HZ OR 60HZ,1MIN.  
 INSULATION RESISTANCE: 500 MEGA OHMS MIN. INITIAL  
 AFTER 500V DC FOR 1 MINUTE.  
 CONTACT RESISTANCE: SINGLE TERMINAL 30 MILLIOHMS MAX.  
 INITIAL 50 MILLIOHMS MAX. AFTER  
 DURABILITY TEST.

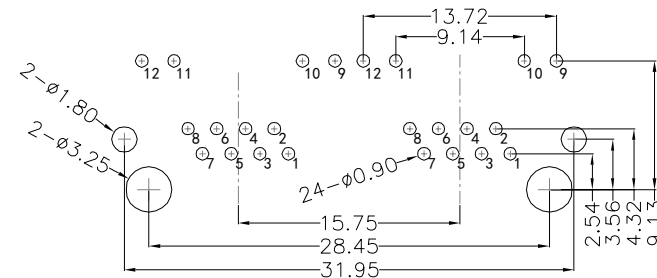

RECOMMENDED PCB LAYOUT  
 VIEWED FROM COMPONENT SIDE

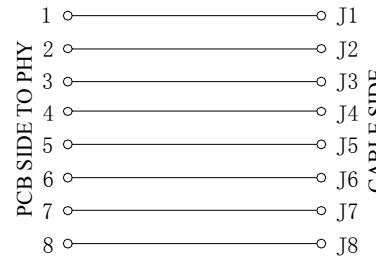

**LED Specification**

Standard LED Color	LED Wavelength	Foward(A)	Foward(V)
Green	569nm	20mA	1.85-2.45V
Yellow	589nm	20mA	1.7-2.2V

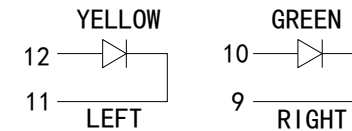

PART NO.	561288DB1A3DY1027	DRAWN	MARK
DWG NO.		CHECK	JOHN
TOLERANCE	X.±0.35 .X±0.30	APPROVE	MELODY

TITLE:	REV. A0	.XX±0.25 .XXX±0.10	SCALE 1:1	UNIT mm	NO	DESCRIPTION
--------	---------	--------------------	-----------	---------	----	-------------

RJ45 1\*2 56带屏蔽带灯