

FEMALE HEADER ROUND PIN DIP DUAL ROW

3624 SERIES - 1.27MM PITCH



Technical Specs

- Insulator: Black Glass filled polyester PPS
- Flammability: UL94V-O
- Sleeve: Brass (H59-3)
- Contact clip (3 finger): Beryllium copper (C17300)
- Accepted pin: $\varnothing 0.38$ to 0.50mm
- Mechanical life: min 500 cycles
- Rated Current: 1A
- Forces: (polished steel gauge $\varnothing 0.41$ mm)
 - Insertion 0.5 N typ
 - Withdrawal 0.2 N typ
- Contact Resistance: max 20m Ω
- Dielectric Resistance: min 500V RMS

Ordering Information

3624D2 - 38 (XX) - AAA B

1. Connector Series

2. (H) Hauteur isolant

- H = 38 (Hauteur isolant : 3.8mm)

3. Number of pins per row

4. Pin Length (064 = 6.4mm)

5. Contact Plating

- A = Tin
- B = Gold Flash (*Standard)
- C = 2U" Gold
- D = 3U" Gold
- E = 5U" Gold
- F = 10U" Gold
- G = Gold Flash/Tin

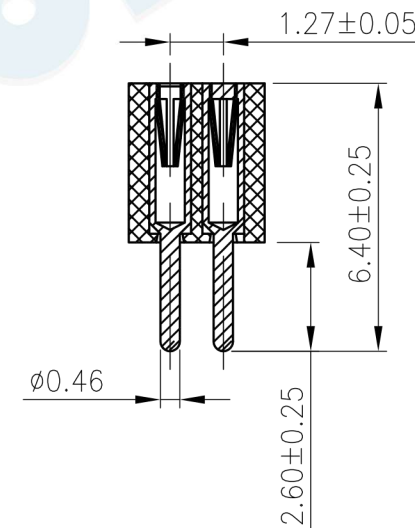
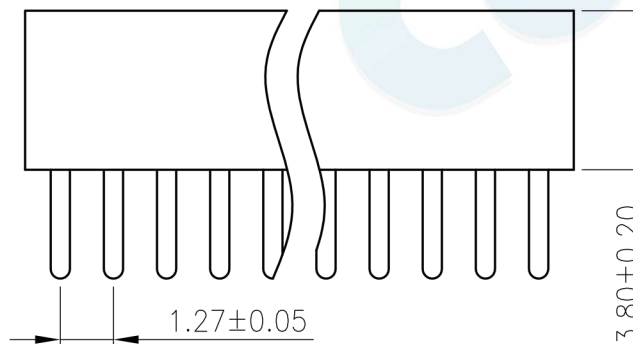
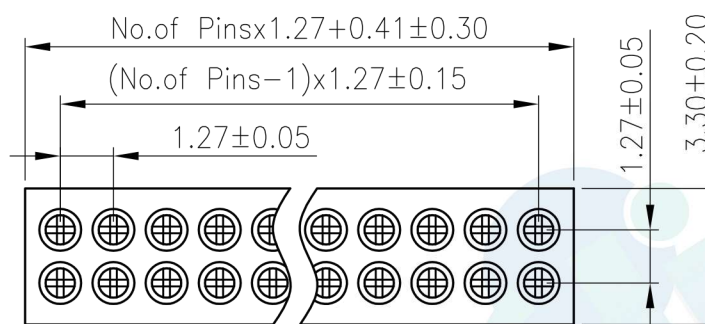
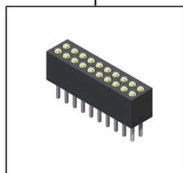

REV	DATE	MODIFICATION DESCRIPTION	CHANGE	OPERATION	DRAW	BEN	12.04.18	SCALE	FIT	PART NO.	TITLE:
A0	2012.04.18	NEW DRAWING		X.X				UNIT	mm	3624D2 - 38XX - XXXX	1.27x3.8 Machine Female Header 180°/L=6.4
				X.XX	CHECK			SIZE	A4		
				X.XXX				SHEET	1/1		
				Angle	APPROVE			PROJ.			
				DIM							
				TOL							

