

EJECTOR HEADER SMT CONNECTOR

3340 SERIES - 1.27MM PITCH



Specifications

- Current rating: 1.0 Amps
 - Contact resistance: 20mΩ max
 - Withstand voltage: 500V AC/DC
 - Insulation resistance: 1000MΩ min
 - Operation temperature: -40°C to +105°C
 - Contact material: Brass
 - Contact plating: Au Or Sn Over Ni
 - Insulator material: Polyester (UL94V-0)
- Standard: PA6T
 - Max. processing Temp: 230°C for 30-60 seconds
260°C for 10 seconds

Recommended P.C.B Layout (Top Side)
(PCB BOARD TOLERANCE ±0.05)

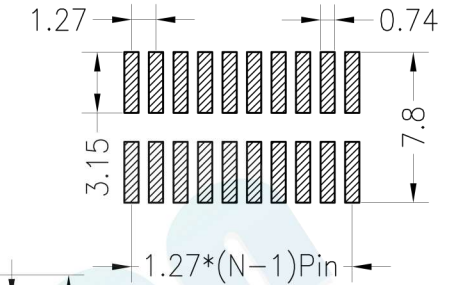

Ordering Information

3340S - XX A B - G S

1
2
3
4
5
6

1. Connector Series

2. Number of pins

3. Contact Plating

- A=Gold Flash
- B= 1.5U" Gold
- C=2U" Gold
- D=3U" Gold
- E= 5U" Gold
- F= Gold Flash/Tin
- G= Tin

4. Insulator Material Option

- A = BK-PBT
- B = BK-PA66
- C = BK-PA6T
- D=BK-PA46
- E=BK-PA9T
- F=BK-LCP

5. Color type

- B = Black
- G = Grey

6. Latch Type

- S = Short Latch

(1). Packaging

Ø=PE Bag 1=Tray 2=Tube

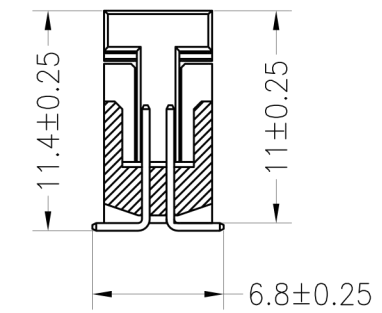
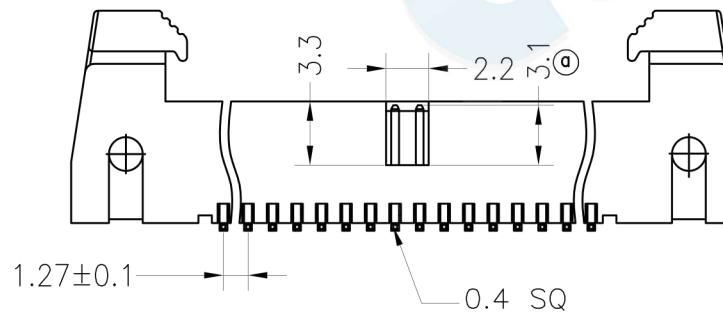
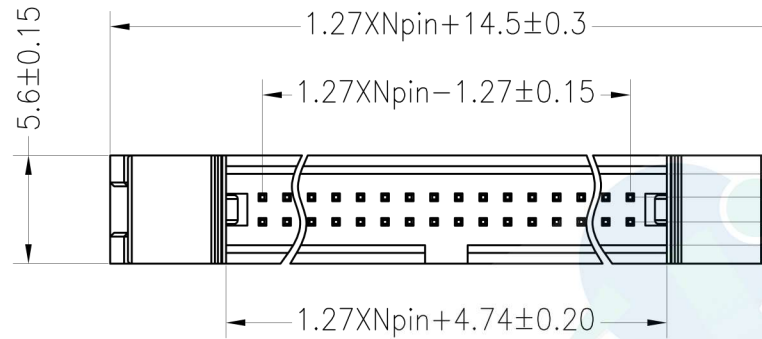

				OPERATION		DRAW	BEN	12.04.18	SCALE	FIT	votre partenaire en électronique	
				X.X	±0.30				UNIT	mm		
				X.XX	±0.20	CHECK			SIZE	A4	PART NO.	3340S-XXXX-XS
				X.XXX	±0.10				SHEET	1/1		
A0	2012.04.18	NEW DRAWING		Angle	±3°	APPROVE			PROJ.	◆	TITLE:	1.27DC2-NPIN SMT L8.8
REV	DATE	MODIFICATION DESCRIPTION		DIM	TOL				5	6	7	8