

WAFER CONNECTOR SMT RIGHT ANGLE

3001 SERIES - 3.00MM



Specifications

- Rated current: 5.0AMP
- Voltage rating: 250V AC/DC
- Contact resistance: 20mΩ max
- Withstand Voltage: 1500V AC/minute
- Insulation resistance: 1000MΩ min
- Operation temperature: -40°C to +105°C
- Contact material: Brass
- Contact plating: Tin Over Ni
- Solder Tabs material: Brass/Tin plated
- Insulator material: Polyester (UL94V-0)
- Standard: LCP
- Max. processing Temp: 230°C for 30-60 seconds
260°C for 10 seconds

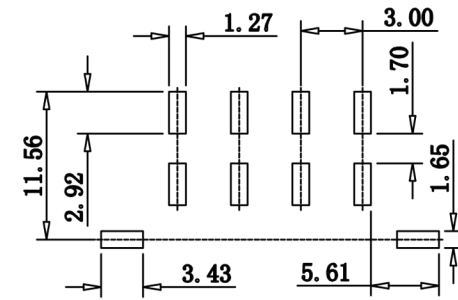
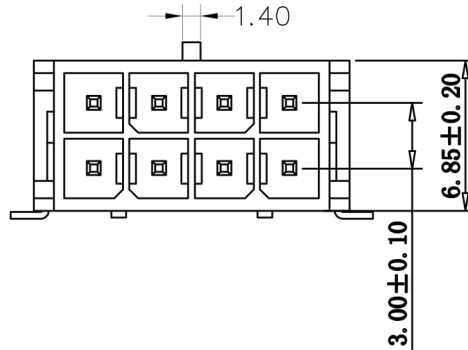

P. C. B. LAYOUT

Ordering Information

3001SR2 - (XX) X X 01 (1)

1. Connector Series
2. Number of pins per row (02→24)
3. Insulator Material Option
 - A = BK-PA6T
 - B = BK-PA9T
 - C = BK-LCP
4. Contact plating
 - A = Gold Flash
 - B = Gold Flash/Tin
 - C = Tin
 - D = Matte-Tin

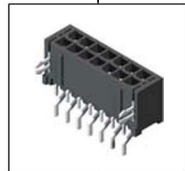

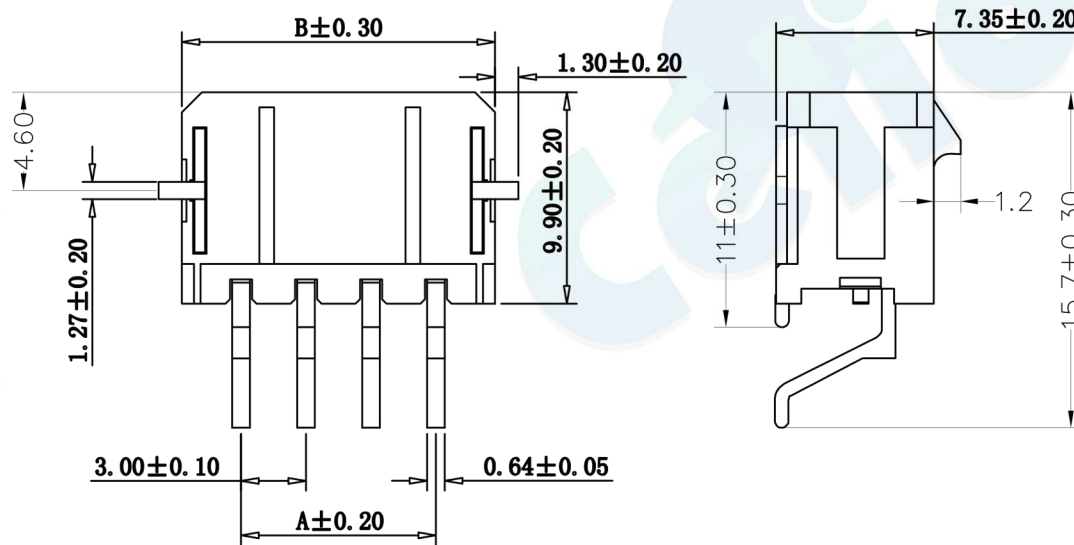

(1). Packaging
∅=Pe Bag 1=Tube 2=Reel



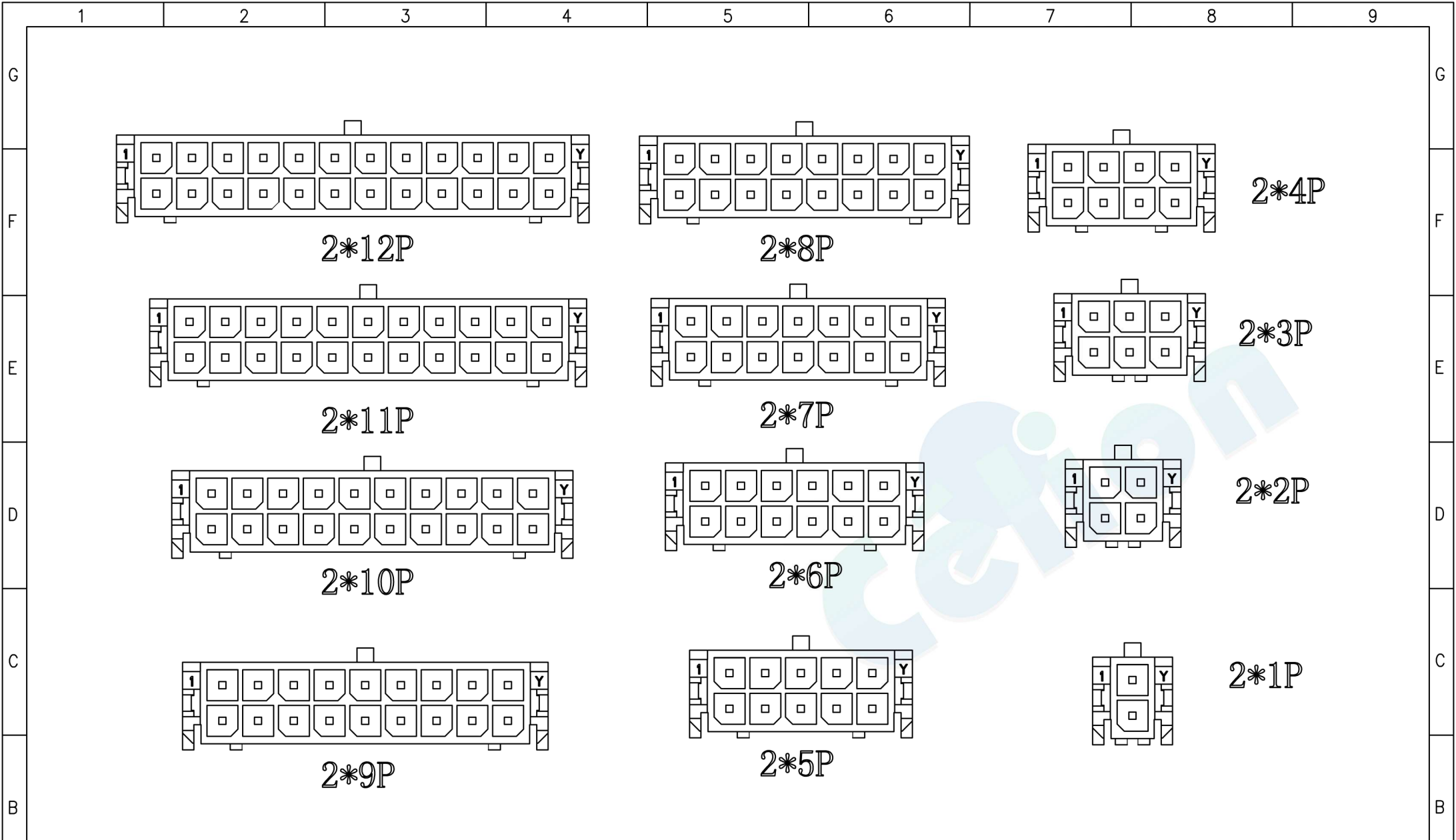

Circuit	Dimensions (mm)	
	A	B
2*01	--	6.65
2*02	3.00	9.65
2*03	6.00	12.65
2*04	9.00	15.65
2*05	12.00	18.65
2*06	15.00	21.65
2*07	18.00	24.65
2*08	21.00	27.65
2*09	24.00	30.65
2*10	27.00	33.65
2*11	30.00	36.65
2*12	33.00	39.65

				OPERATION		DRAW	BEN	12.04.18	SCALE	FIT	 votre partenaire en électronique		
				X.X	±0.30				UNIT	mm			
				X.XX	±0.20	CHECK		SIZE	A4	PART NO.			3001SR2 - XXXX 01
				X.XXX	±0.10	APPROVE		SHEET	1/1	TITLE:			3.00mm Npin 90° SMT Wafer
REV	DATE	MODIFICATION DESCRIPTION	CHANGE	DIM	TOL			PROJ.					

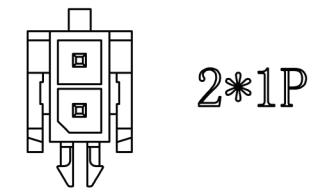
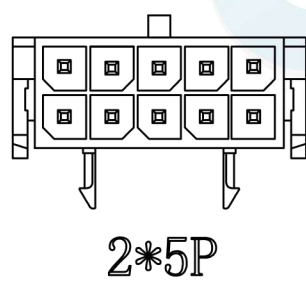
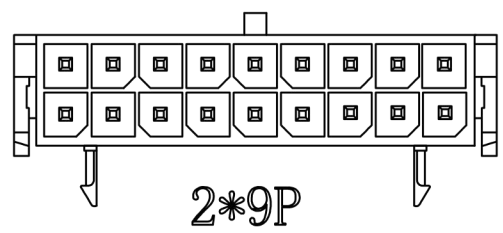
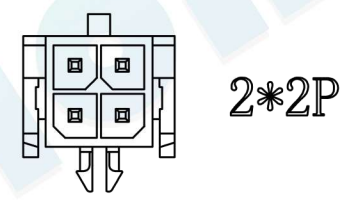
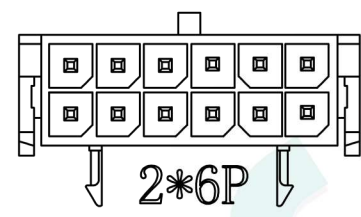
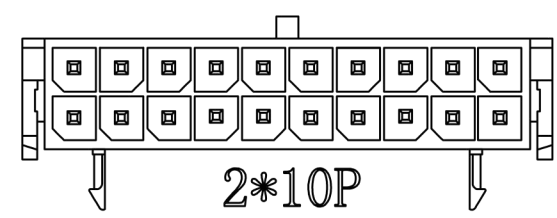
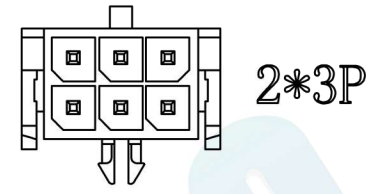
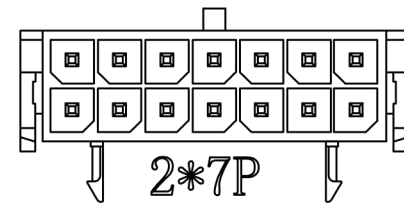
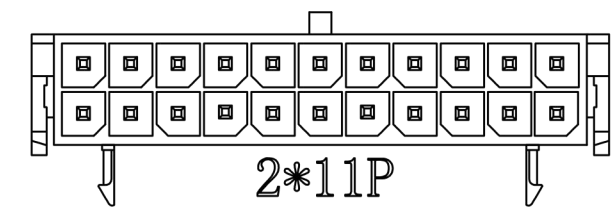
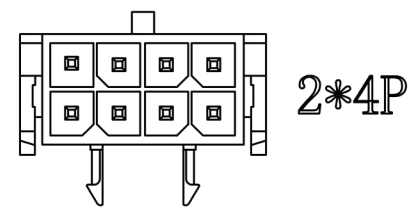
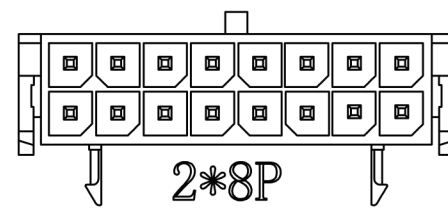
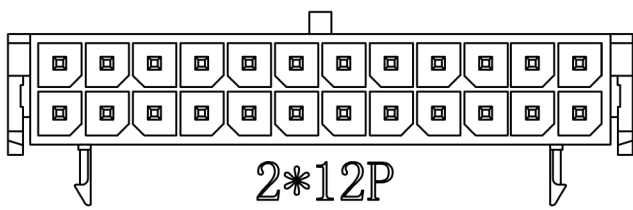

				OPERATION		DRAW	BEN	12.04.18	SCALE	FIT	 votre partenaire en électronique				
				X.X	±0.30				UNIT	mm					
				X.XX	±0.20	CHECK		SIZE	A4	PART NO.				3001SR2 - XXXX 01	
				X.XXX	±0.10	APPROVE		SHEET	1/1	TITLE:				3.00mm Npin 90° SMT Wafer	
REV	DATE	MODIFICATION DESCRIPTION	CHANGE	Angle	±3°				PROJ.						
				DIM	TOL										



				OPERATION		DRAW	BEN	12.04.18	SCALE	FIT	 votre partenaire en électronique			
				X.X	±0.30				UNIT	mm				
				X.XX	±0.20	CHECK	SIZE	A4	PART NO.	3001SR2 - XXXX 02				
				X.XXX	±0.10	APPROVE	SHEET	1/1	TITLE:	3.00mm Npin 90° SMT Wafer				
REV	DATE	MODIFICATION DESCRIPTION	CHANGE	Angle	±3°				PROJ.					
				DIM	TOL									