

10 9 8 7 6 5 4 3 2 1

PART NO. 254500TA301  
 DWG NO. C2545TA

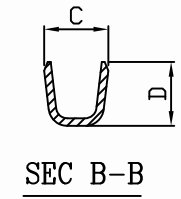
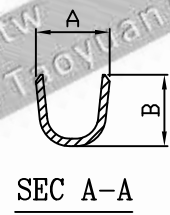
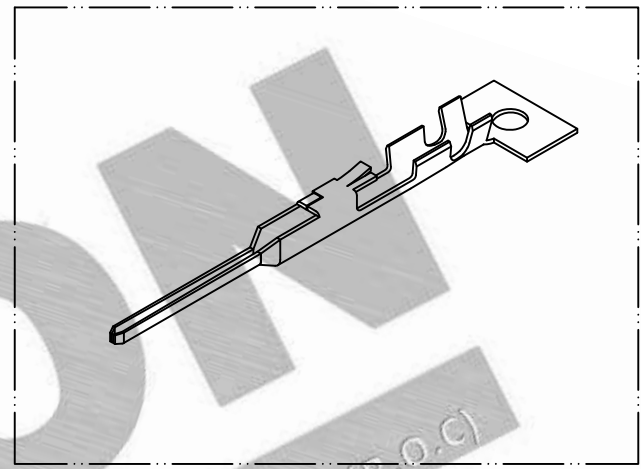
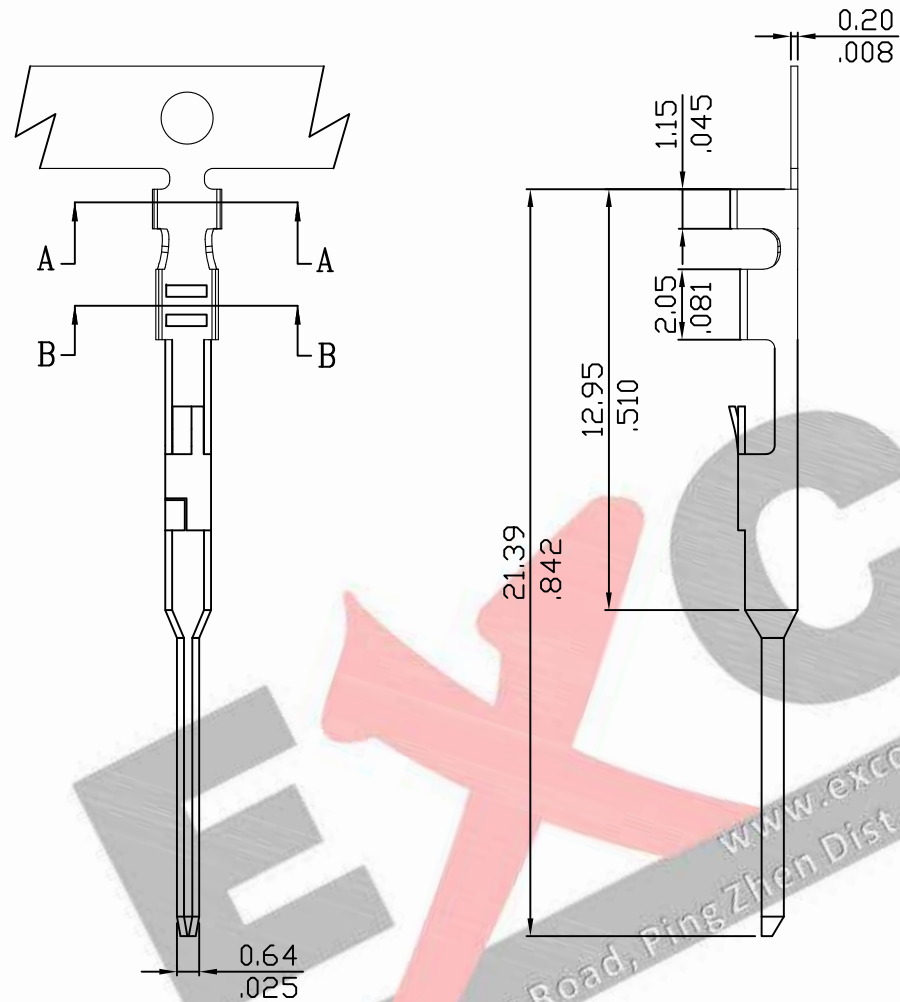

**NOTE:**

1. Terminal Material: phosphor bronze
2. Plated: Tin plated 50u"min.
3. Applicable wires: AWG#28~#24
4. Insulation O.D.: 1.2~1.7mm
5. Q'ty / reel: 15,000 PCS

				UNLESS OTHERWISE SPECIFIED TOLERANCES		<b>EXCON</b> EXCON TECHNOLOGY COMPANY
				3 PLACE ±0.5 ±0.10		
				2 PLACE ±1.5 ±0.25		PART.NO
				1 PLACE ±2.0 ±0.50		
REV.	REVISION			DIS	DATE	ANGLE DIM
SCALE	REV.	PAGE:	UNIT	mm		
3/1	A	1	THIRD ANGLE PROJECTION			C2545TA
						PART.NO
						254500TA301

F  
E  
D  
C  
B  
A

F  
E  
D  
C  
B  
A

10 9 8 7 6 5 4 3 2 1

PART NO. 254500TCxxx  
 DWG NO. C2545TC

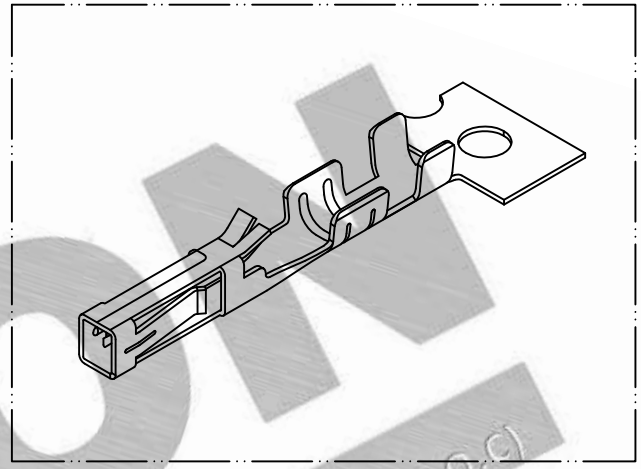
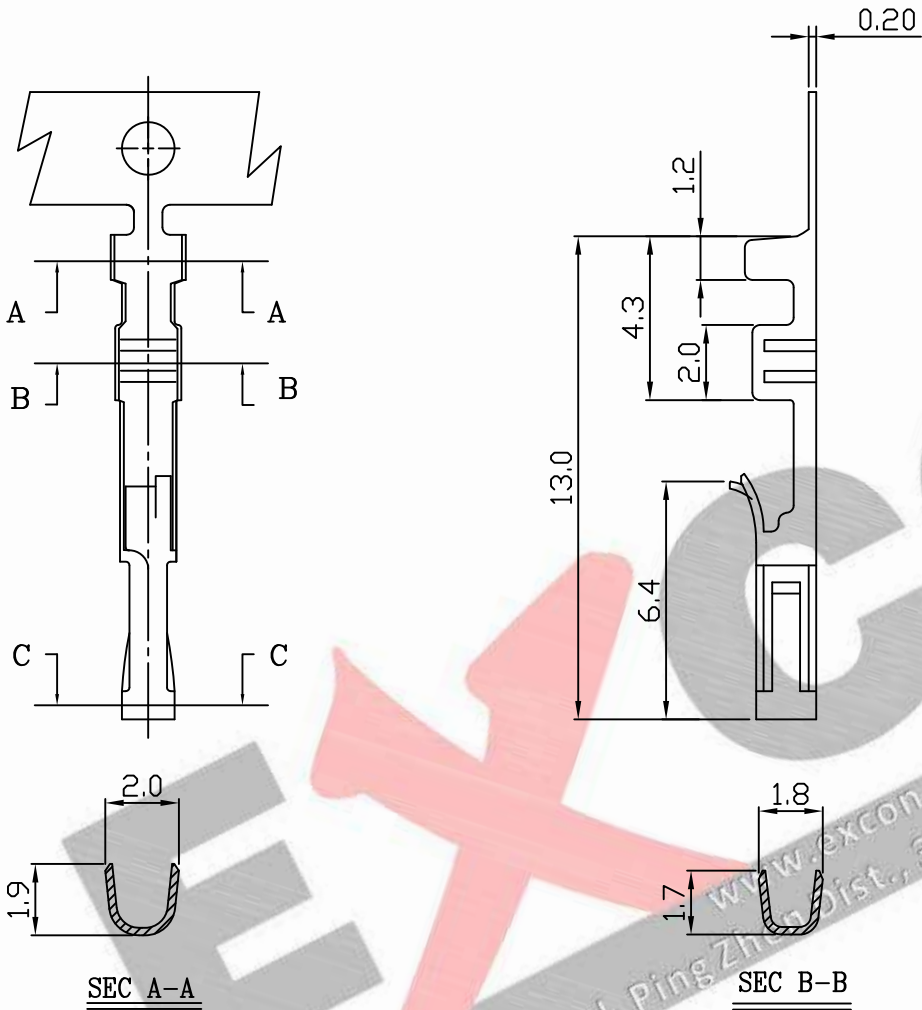

- NOTE:
1. Terminal Material: phosphor bronze
  2. Plated: Tin and gold.
  3. Applicable wires: AWG#28~#24
  4. Insulation O.D.: 1.2~1.7mm
  5. Q'ty / reel: 15,000 PCS

Part No.	Wire Range	Insulation O.D.	Material	Finish	Q'ty/reel
254500TC351	AWG#28~#22	1.2-1.7mm	Phosphor	Tin pre-plated	15,000pcs
254500TC501	AWG#28~#22	1.2-1.7mm	Phosphor	Gold flash	15,000pcs
254500TC503	AWG#28~#22	1.2-1.7mm	Phosphor	Gold 15u"	15,000pcs

UNLESS OTHERWISE SPECIFIED TOLERANCES  
 3 PLACE ±0.5 ±0.10  
 2 PLACE ±1.5 ±0.25  
 1 PLACE ±2.0 ±0.50  
 ANGLE DIM



REV.	REVISION	DIS	DATE	SCALE	REV.	PAGE:	UNIT	mm	DWG NO:	PART.NO
3/1	A	1					THIRD ANGLE PROJECTION		C2545TC	254500TCxxx