

WAFER CONNECTOR HOUSING

2541 SERIES - 2.54MM



Specifications

- Withstanding Voltage: 1000V AC/DC
- Insulation resistance: 1000MΩ min
- Insulator material: Polyester (UL94V-0)
- Standard: PBT
- Max. processing Temp: 180°C for 30-60 seconds
200°C for 10 seconds

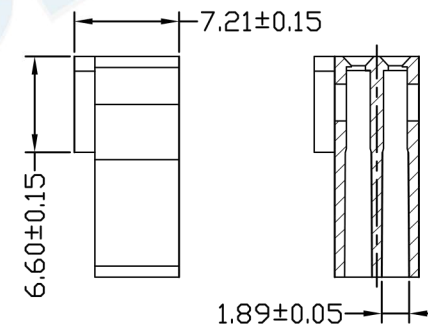
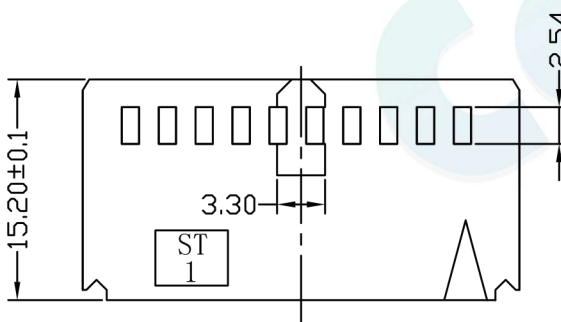
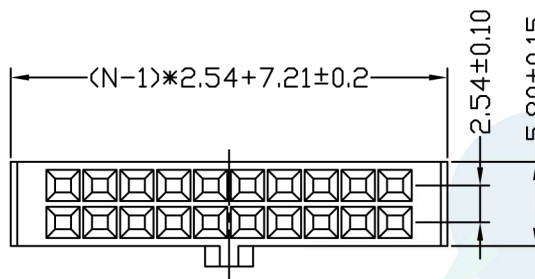
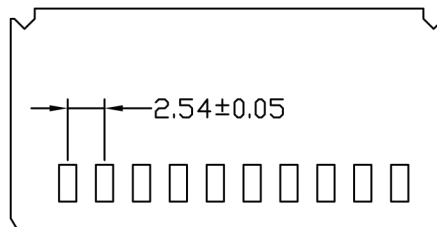

Ordering Information

2541H - (XX) X B

1
2
3
4

1. Connector Series
2. Number of pins per row
3. Contact plating
 - A = BK-PBT
 - B = BK-PA66
 - C = BK-PA6T
 - D = BK-PA46
 - E = BK-LCP
4. Color
 - B = Black

				OPERATION		DRAW	BEN	12.04.18	SCALE	FIT	 votre partenaire en électronique	
				X.X	±0.30				UNIT	mm		
				X.XX	±0.20	CHECK			SIZE	A4	PART NO.	2541H - XXXX
				X.XXX	±0.10				SHEET	1/1		
A0	2012.04.18	NEW DRAWING		Angle	±3°	APPROVE			PROJ.	◆	TITLE:	2.54mm
REV	DATE	MODIFICATION DESCRIPTION	CHANGE	DIM	TOL							

WAFER CONNECTOR TERMINAL

2541 SERIES - 2.54MM



Specifications

- Rated current: 3.0AMP
- Contact resistance: 20mΩ max
- Contact material: Phosphore Bronze
- Contact plating: Au Or Sn Over Ni

Ordering Information

2541T - X P
1 2 3

1. Connector Series

2. Contact plating

- **A** = Gold Flash/Tin
- **B** = AU1.0" Gold Flash/Tin
- **C** = Tin

3. Contact material Option

- **P** = Phosphore Bronze

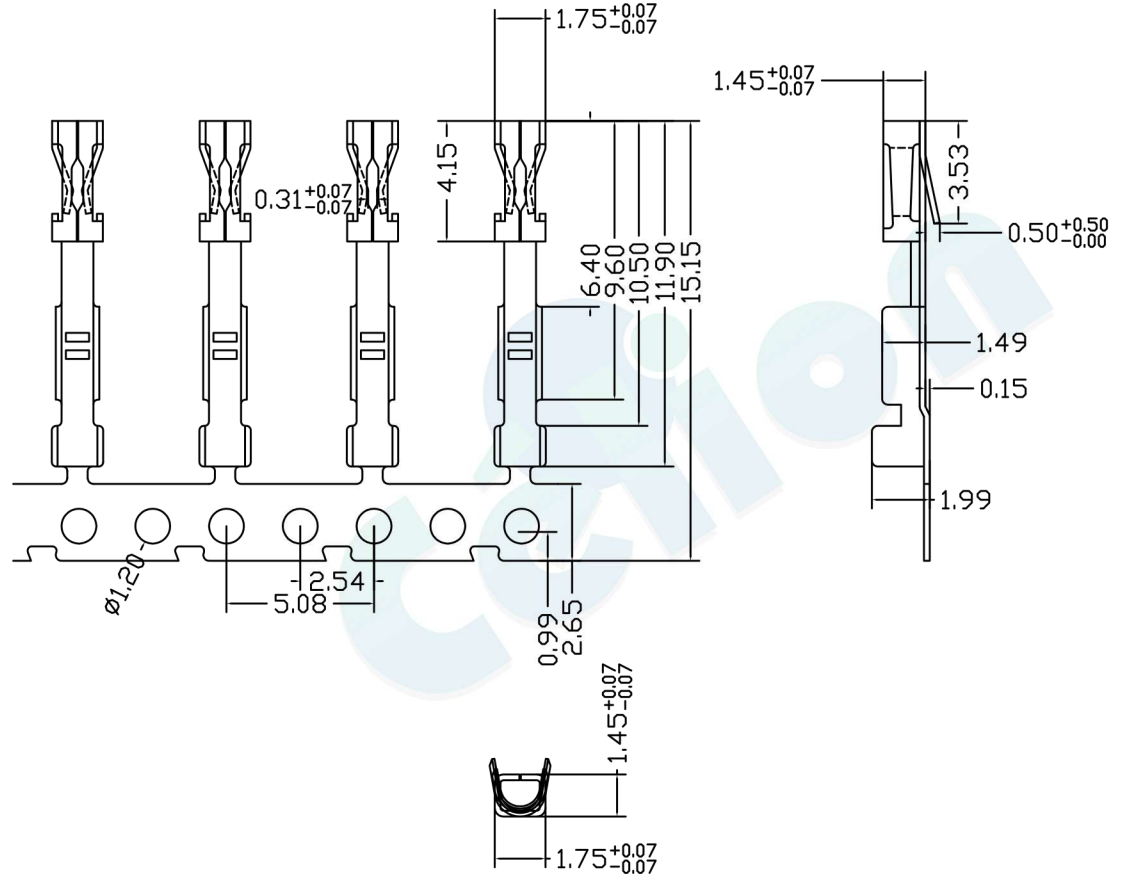

				OPERATION		DRAW	BEN	12.04.18	SCALE	FIT	 votre partenaire en électronique PART NO. 2541T - XX TITLE: 2.54mm AMP	
				X.X	±0.30				CHECK	UNIT		
				X.XX	±0.20	SIZE	A4					
				X.XXX	±0.10	SHEET	1/1					
A0	2012.04.18	NEW DRAWING		Angle	±3°	APPROVE		PROJ.				
REV	DATE	MODIFICATION	DESCRIPTION	CHANGE	DIM	TOL						