

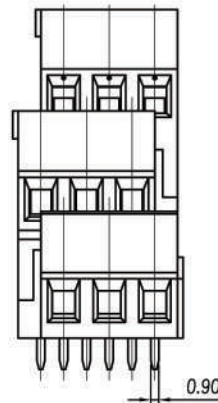

CÉLION

product specification

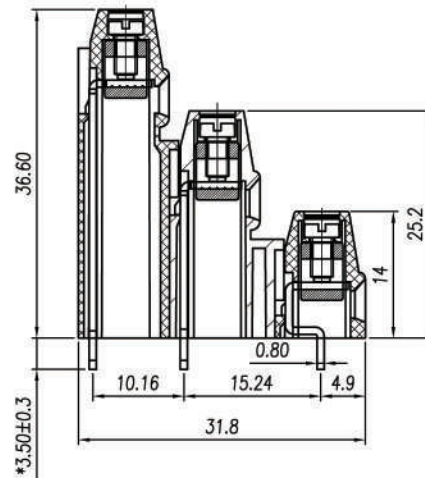
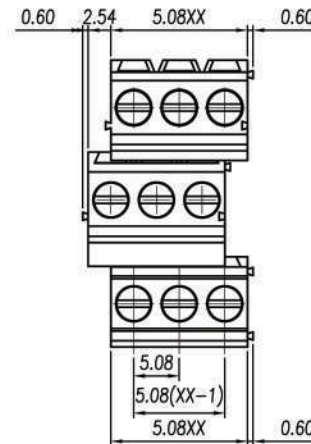
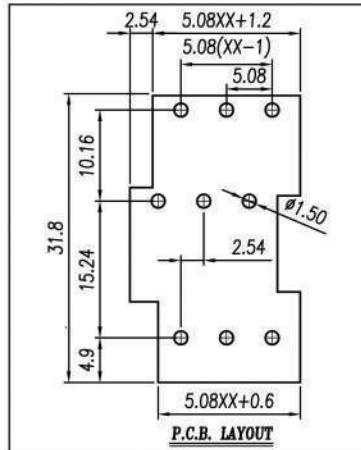

Approvals

UL-cUL not approved
VDE not approved

Electrical

Standard
Rated voltage 250V
Rated current 18A
Contact resistance 20mΩ
Insulation resistance 500MΩ/DC500V
Withstanding voltage AC 2000V/1 min
Wire range 30-12 AWG 2.5 sqmm

Torque 0,4 Nm (3.6 Lb.in)
Temp. Range -40°C + 105°C
Stripping length 6-7 mm
Max sold. time +250°C for 5 sec.

Dimensions

Pitch 5.08 mm
Poles 2+2+2 ÷ 24+24+24

Material

Housing PA 66 UL 94V0
Pin Brass, tin plated
Cage Brass, Ni plated
Screws Steek Zn plated
Slide Block
Nut screw
Clamp

Version/Version Data/Date

2014/1 13/06/14

General description of ordering code

Series	n. poles	pitch	version	color	custom
MRT52	2-24	5.08	L		

UNITS:mm SIZE: A4

CELION SAS - GRIGNY (FRANCE)

Series:

MRT52-5.08-L